

Ing. Robert Forbus

7,62 x 39 AKM Barrel Izhevsk Standard

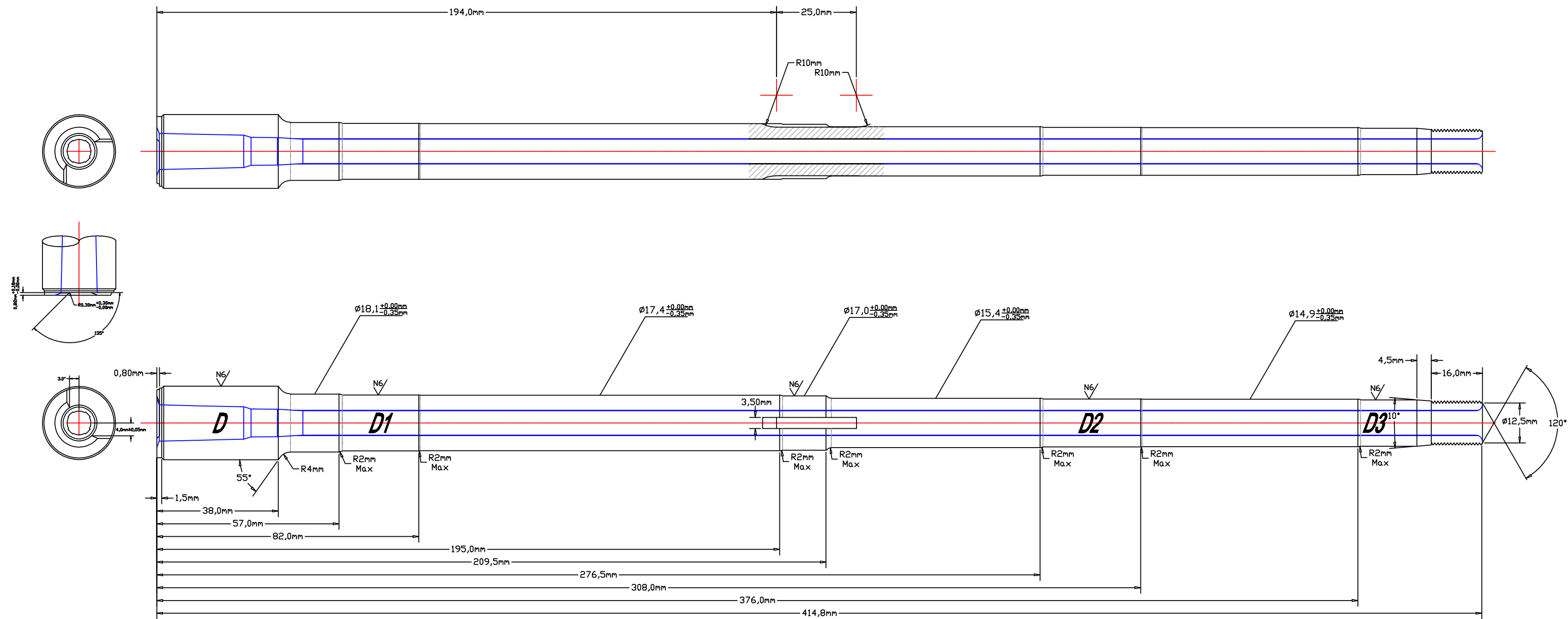

	0	I	II	III
D	23,15 ^{+0,00} _{-0,02}	23,07 ^{+0,00} _{-0,02}	23,13 ^{+0,00} _{-0,02}	
D1	17,53 ^{+0,00} _{-0,02}	17,57 ^{+0,00} _{-0,02}	17,65 ^{+0,00} _{-0,02}	
D2	15,85 ^{+0,00} _{-0,02}	15,84 ^{+0,00} _{-0,02}	15,85 ^{+0,00} _{-0,02}	15,12 ^{+0,00} _{-0,03}
D3	14,51 ^{+0,00} _{-0,02}	14,54 ^{+0,00} _{-0,02}	14,55 ^{+0,00} _{-0,02}	14,62 ^{+0,00} _{-0,03}

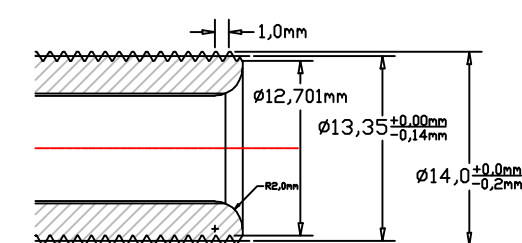
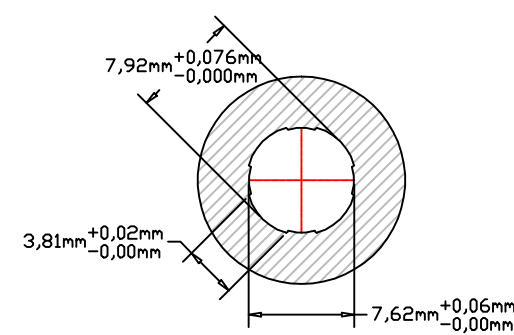
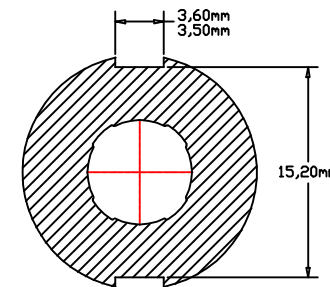
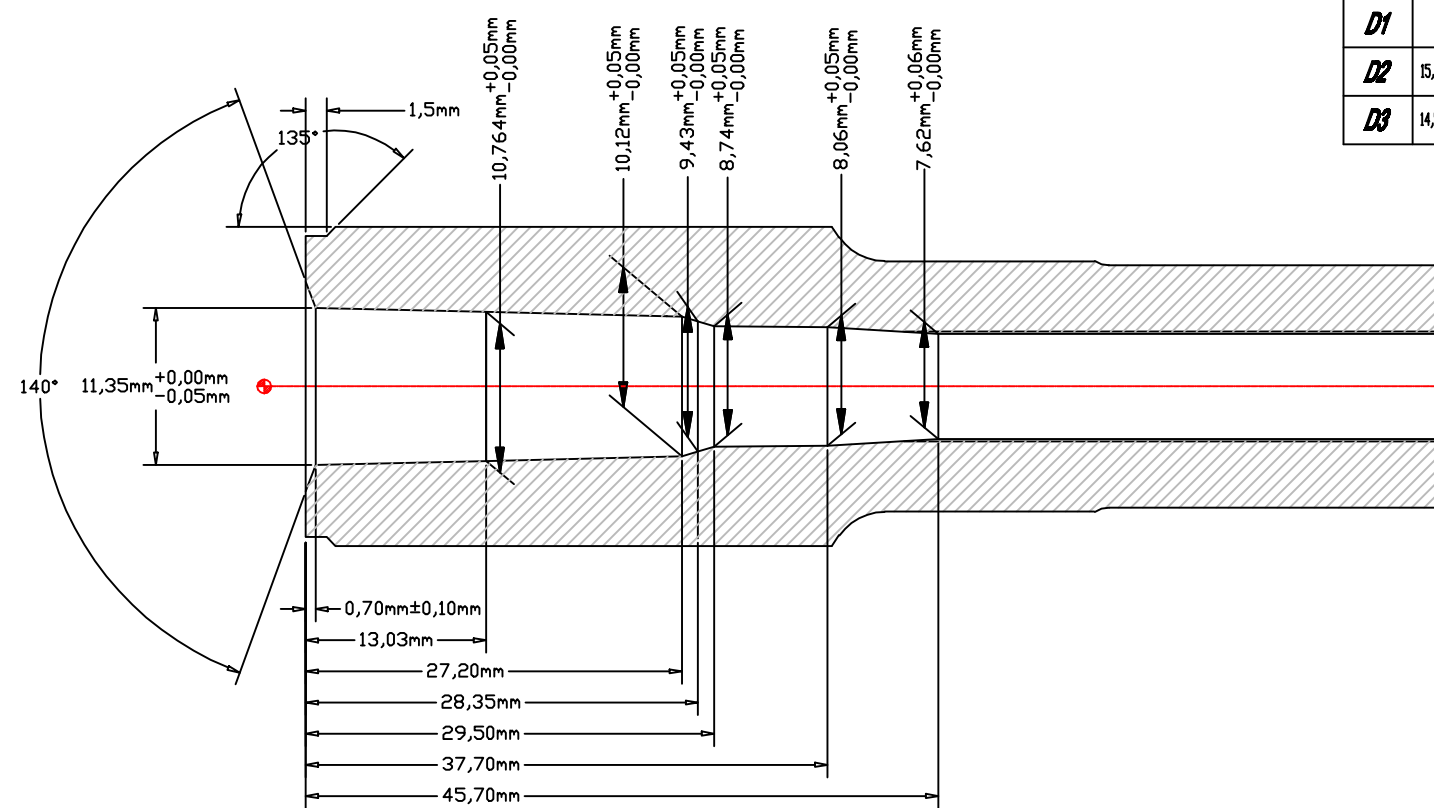

Ing. Robert Forbus